



**IR 1000 BGA Rework Station**  
**Operation and Maintenance Manual**

**Manual Number 5050-0571**



## PACE IR 1000

	<u>Page</u>
Packing Contents, Standard Items .....	3
Specifications .....	3
Parts Identification.....	4,5,6
Safety Information .....	6
Features .....	6
General Heating Information on Temperatures and Ramp	
Rate .....	6
Set Up .....	8
Start up.....	8
System Operation.....	9
General Menu Operation .....	9
Setup Menu.....	9,10
Edit Menu.....	10,11,12,13
Save Menu.....	13,14
Recall Menu.....	14
Maintenance.....	14
Inserting/changing Vacuum Pik .....	14
IR Heater Elements Replacement.....	15
Trouble Shooting.....	16
IR 1000 Abbreviations.....	17
Service and Warranty .....	18
Contact Information .....	19

**Packing Contents. Standard Items**

Description	Part Number
IR 1000 (Domestic)	8007-0536 (120V)
IR1000E (Export)	8007-0537 (230V)

4058-0004-01	Stencil, 0.5 IN, IR-1000	1
4058-0004-02	Stencil, 0.75 IN, IR-1000	1
4058-0004-03	Stencil, 1.0 IN, IR-1000	1
4058-0004-04	Stencil, 1.25 IN, IR-1000	1
4058-0004-05	Stencil, 1.5 IN, IR-1000	1
6000-0380	Assembly, Thermo Couple Mount, IR1000	1
7008-0300	Assembly, IR-1000, 120V, (8007-0536)	1
7008-0301	Assembly, IR-1000, 230V, (8007-0537)	1
7021-0010	Thermocouple Probe, PCB, IR1000	1
1332-0094	Domestic Power Cord, (8007-0536)	1
1332-0093	Export Power Cord, (8007-0537)	1

**Specifications:**

**IR 1000**

Part Number	7008-0300 (Domestic)
	7008-0301 (Export)
Dimensions	381mm <b>H</b> x 381 mm <b>W</b> x 457.2 mm <b>D</b> (15" x 15" x 18")
Weight	20 kgs (35 lbs)
Power Requirements	115 VAC, 50/60 Hz (Domestic), 9.6A (1100W)
	230VAC 50/60 Hz (Export) 4.8A (1100W)
Pre-Heater	400 watts, 65 to 176 °C (150 to 350 deg °F)
Main (Top) Heater	IR, 250 watts X 2 (500W Total),
	Power Levels 0 – 20 (20 = Full power)
Vacuum	5.9 in Hg
PC Board Size	305 x 305 mm, 12" x 12"

## IR 1000 BGA Rework Station Parts Identification

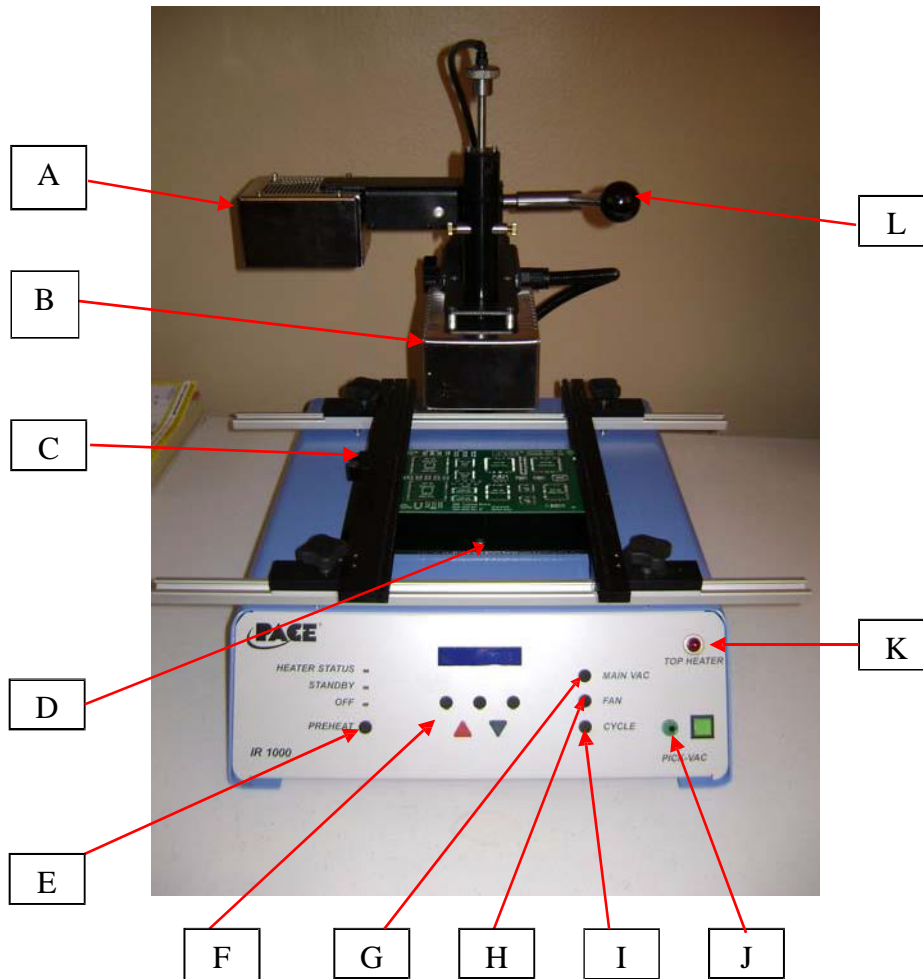

**Figure 1 Front of IR 1000**

- |    |                                       |   |
|----|---------------------------------------|---|
| A. | Cooling Fan                           | The component and PCB are cooled by the cooling fan; can be activated manually, or automatically after the reflow cycle is complete.  |
| B. | Reflow Head                           | Contains the Top-side heater and it moves up and down via a manual adjustment lever. The vacuum Pik is spring controlled to control upward force; the vacuum Pik is adjustable with a lock in place function.   |
| C. | Board Holder                          | Mounts and positions the PCB into a secure position.  |
| D. | Pre-Heater                            | IR heating source used to provide bottom-side board Pre-heating.  |
| E. | Pre-heat Button                       | Allows the Pre-Heater to be put into a standby mode, or it can be turned off when not in use. The top LED will indicate status of Pre-Heater with a green light indicating that the Pre-Heater is ready, and a yellow light indicating that it is still coming up to temperature. |
| F. | Function Buttons<br>"Black Soft Keys" | Allows selection of the programming functions, and control of the process parameters.   |

- G. Main Vacuum Button Switches the main vacuum on/off manually.
- H. Fan Button Manually enables the operation of the fan; fan must be in position over the Component/PCB.
- I. Cycle Start Button Manually starts/stops the desired Profile Cycle.
- J. Pik-vac connection and switch. Manually turns on/off the Pik-Vac pump; allows for the connection of an external Vacuum Pick.
- K. Top Heater Active Indicator Light Indicates that the Top Heater is active.
- L. Vertical Adjustment Lever Raises and lowers the Top Heater Head.

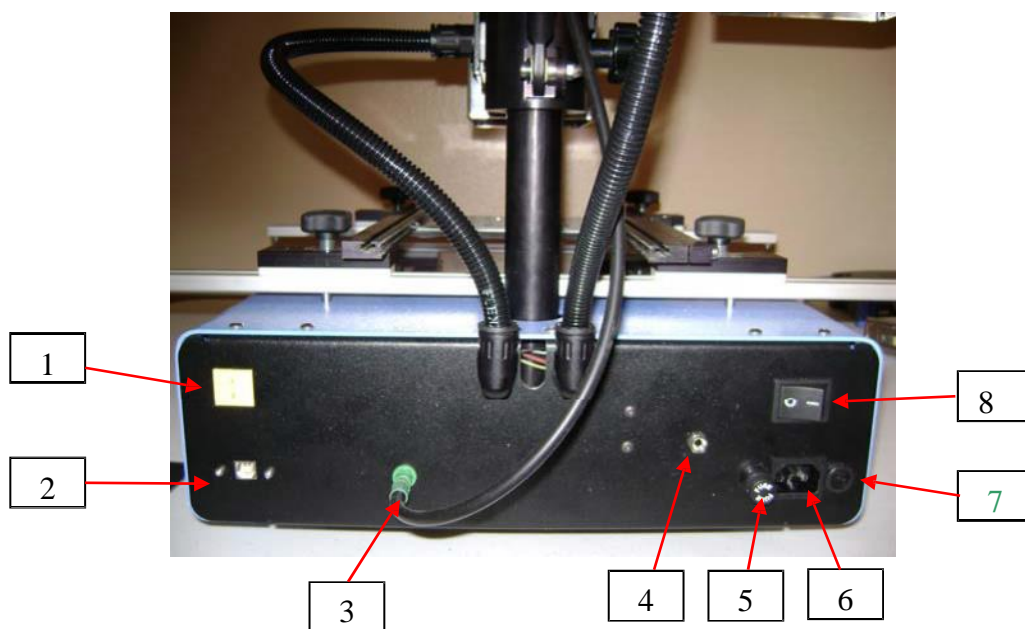

**Figure 2 Rear Panel**

- 1. K-Type thermocouple input Thermocouple used for profiling in the “Learn Mode”. Used to measure temperature on top of the component, as the primary means of developing a profile.
- 2. USB connection for External Computer Used for interconnection of an external computer for profiling and programming.
- 3. Pik-Vacuum connection Used for connecting main Pik vacuum to the heater head.
- 4. External Ground. Used for connecting an external ground
- 5. Main Fuse Domestic – 15A SB, Pace # 1159-0279  
Export – 7.0A Time Lag, Pace # 1159-0278
- 6. AC power connection Domestic – 115 VAC, 15.0A  
Export – 230 VAC, 7.0A

- 7. Fuse Domestic – 0.5A SB, Pace # 1159-0248  
Export – 0.5A Time Lag, Pace # 1159-0213
- 8. On / Off Switch Used to turn the system on/off. When starting the system, always turn on the **IR 1000 before starting the PC software.**

**a) Safety Information**

- a. Do not contact the Top/Bottom heater or its peripheral parts during operation.
- b. Once turned off, let the heaters cool completely before contacting. The Heaters are hot and will cause burns.
- c. When using fluxes, use fume extraction equipment or use in a well-ventilated area to minimize operator exposure to fumes.
- d. Do not use near combustible vapors.
- e. Do not leave the equipment unattended when in use.
- f. Do not open the unit without disconnecting the main power cord.
- g. IR 1000 should only be used by a trained operator.

**b) Features**

- a. The IR 1000 is ideal for post assembly rework, repair, and low volume/short run production operations. The IR 1000 can remove and install PBGAs, CSPs, FCs, LGAs, LCC's, QFN's and other SMDs.
- b. Featuring unparalleled thermal performance, PACE BGA Rework Stations flexibility and state of the art process software means no other system is easier to use. The IR 1000 is a microprocessor driven, semi-automated system that does not require an external PC. The IR 1000 uses a combination of IR top heating coupled with powerful IR bottom heating for an effective, repeatable heating process.
- c. Economical and easy to use, PACE BGA Rework Systems deliver high-end BGA/CSP functionality, moving far beyond expensive, bulky rework machines by offering unparalleled performance at an affordable price.
- d. The optional software package offers an easy operator interface and greater flexibility than the front panel.

**4. General Heating Information on Temperatures and Ramp Rates**

Acceptable ramp rates and maximum temperatures should be obtained from the component manufacturer. Typical ramp rates are 2-5 °C/s (4-9 °F/s) for plastic parts and 1 °C/s (2 °F/s) for ceramic parts. It is recommended to select a maximum temperature below the manufacturer's specification to provide for a margin of safety; typically, 20 °C below maximum specified temperature is selected if possible. (Depending on the various solders used on components) This may not be possible with some of the lead free alloys used.

**Pre-Heat Phase**

- 1. In a "step profile", the PCB and component package should reach a stable temperature of 100-110°C. If plotting the temperature curve with the optional software, the trace will usually level off within this temperature range.
- 2. If a "linear slope profile" is desired, pre-heat and soak phases are combined. Both the component package and the PCB are warmed at a constant ramp rate until the desired temperature is reached. The ramp rate is controlled by the top heater power setting, and the distance the top heater is from the PCB board.

### **Soak Phase**

The soak phase is a crucial part of the process. During this period, the flux activates and drives off volatiles and excess flux. A temperature of 145-175 °C (determined by the activation temperature of the flux used) should be maintained for approximately 20-40 seconds. This allows for uniform ramping across the entire package and PCB during reflow.

### **Reflow Phase**

During this phase, the solder reaches solder melt and forms joints between the package and the lands. It is critical for all areas of the component to reach solder melt together; all solder joints should remain in a liquid state for at least 10-20 seconds. Generally, plastic packages should not be exposed to temperatures higher than 240 °C. Always consult the device specifications for maximum temperature recommendations. As a rule of thumb, a safe "maximum temperature" is the maximum temp specified by the manufacturer minus 20 °C.

**The lowest heater set temperatures possible should always be used to ensure safety of the device and PCB.**

### **Dwell Phase**

During this phase, the reflow temperature is reached and the temperature stays at reflow for a set duration of time; this is used to ensure that the solder is reflowed throughout. A dwell phase is not always necessary for successful profiles.

### **Cool Down Phase**

The cool down phase is necessary to bring the temperature of the component package, solder joints, and PCB under solder melt temperatures. Some types of components (like CBGAs) should be allowed to cool without external assistance from the cooling fan. When installing CBGAs, do not move the fan when "Raise Heater and Move to Fan Position" message come up. Only use cooling fan when installing/removing plastic components.

5. **Set-Up**

Parts List			
ITEM	QTY	PART NUMBER	DESCRIPTION
1	1	6993-0289	PC BOARD HOLDER
2	4	1405-0966	SCREW, 6-32 x 0.5
3	4	1215-0257	SPACER, #6 x 0.25

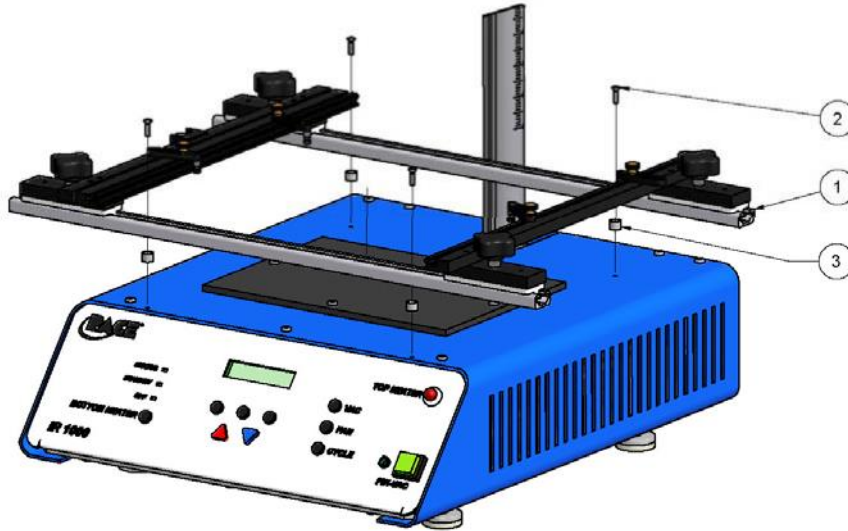

**CIRCUIT BOARD HOLDER INSTALLATION PROCEDURE**

The Board Holder Assembly is shipped uninstalled to prevent damage during transit.

**Attach the board holder (1) using four screws (2) and four spacers (3) as shown in the figure (above/below/to the right/to the left).**

**System Set-up**

- a. Connect power cord.
- b. If using the optional PC software, connect USB cable between the external PC and the USB port of the BGA Rework Station.
- c. Connect K-Type thermocouple probe into the back of unit
- d. Always start machine before PC software

6. **Start up**

- a. Turn on power switch on rear of unit, and the following menu will be displayed.
- b. The digital display on the front panel will alternate from profile title to profile number, or if profile is a "learn mode" then display will be as followed:  
"Profile = XX" <-> " Learn Mode "

**Note: If profile is a Learn profile, then the thermocouple probe**



needs to be plugged into the back of the system, or an "External Thermocouple Open Sensor Error" will be displayed.

- c. The Pre-heater status lamp will illuminate to an amber color. *Note:* The pre-heater status lamp will change to green when the heater has reached temperature. **Note: The Set temperature of the Pre-Heater is the set temperature of the lower heater**

## 7. System Operation

### General Operation (Not in Learn Mode)

- a. Insert a proper size vacuum cup to the main vacuum. The diameter must be smaller than the flat part of the top of the component. **Always use the smallest sized vacuum cup that will work for the component to be installed or removed.**
- b. Place the Printed Circuit Board in the board holder, and align the component to be removed or installed on the PCB. Align the component below the vacuum pick. Using the manual elevation lever, lower the heater head to the desired distance from the PCB.
- c. Recheck the position of the component on the PCB; insure that it is aligned correctly. Press the Recall Button (Soft-Key #3) to choose an existing profile.
- d. Select the Profile that you wish to run from the previously installed profiles. **Note: An infinite amount of profiles can be saved.**
- e. When the Pre-Heater status lamp has changed to green, press the cycle button to start **(The cycle will not start until Pre-Heater is up to temperature)**
- f. The Heater Head distance = XX (distance set in edit menu) will be displayed on the menu. Press OK (Soft-key #1) to start the cycle, or wait 15 seconds and the cycle will start automatically. Press Exit (Soft-key #3) if head distance is incorrect.
- g. The system will run through all 4 stages of the profile (Pre Heat, Soak, Reflow, Dwell)
- h. After the Reflow/Dwell stage, the system will prompt you to move the fan into position over the component to be cooled; Use the manual lever to move the fan into position over the PCB (CBGAs do not need fan cooling after Dwell stage only plastic components)
- i. Caution: Component package and PCB will be **HOT**. Do not touch the component or the PCB until it has fully cooled.

## 8. General Menu Operation:

The three black soft keys are used to select options that are displayed, and the "Red Up" key and the "Blue Down" keys are used to change the parameter of the display. When you accept options by selecting Yes (Usually Soft-Key #1), the menu will move to the next display option.

## 9. Setup Menu:

The Setup menu is used to setup the following options:

Password – Used for protection on the "Edit Menu" to only allow authorized operators to change setup profiles.

Learn Mode Capability in Edit menu – This option will allow a "Learn Mode" profile to be setup in the edit menu.

Deleting Profile – This section will allow you to delete profiles that you no longer use.

The Setup menu is entered by powering up the IR 1000 while holding the (Black Soft-key #1) down as the power is turned on, and holding it until the password message is displayed. The following message will then be displayed:

"Password Needed?"  
"Same No Yes"

- Pressing the Soft-key # 1 (Same Password) will move you onto the next menu item, keeping the same password that was in the system.
- Pressing the Soft-key # 2 (No) will remove the password, and move onto the next menu item.
- Pressing the Soft-key # 3 (Yes) will bring up the password select menu as shown below:

```
"Ent New Password"
"Enter      Exit"  <->  "Password = 0000"
```

Using the "Red Up" and "Blue Down" keys, a password from 1 to 9999 may be set. A password of "0000" is considered to be no password.

Pressing Enter (Soft-key #1) will enter a password and move to the next menu item.

This menu will let you enable or disable the Learn mode capability.

```
"Learn = Enabled" or "Learn = Disabled"
"(Soft-Key #1 Yes)      (Soft-Key #2 No)"
```

**Note: In "Learn Mode" thermocouples must be plugged into the back of the unit**

- Pressing "Yes" (Soft-key # 1) will accept the display status and move on to the next menu item.
- Pressing "No" (Soft-key # 3) will change the status.

```
"Delete Profiles?"
" Yes      No  "
```

- Pressing "Yes" (Soft-key # 1) will enter the "Delete Profiles" menu item.
- Pressing "No" (Soft-key # 3) will move onto the next menu item.

```
"Delete Profile  "
"Enter      Exit"  <->  " Number -- "
```

Use the "Red Up" and "Blue Down" keys to select the profile you want deleted, and then press Enter (Soft-key #1) to delete desired profile.

The Exit menu will appear at the end of the setup.

```
" Exit Setup ? "
" Yes      No  "
```

- Pressing "Yes" (Soft-key # 1) will exit the setup menu, and save all changes.
- Pressing "No" (Soft-key # 3) will move you back to the beginning of the setup menu.

## 10. Edit Menu:

The edit menu will allow the operator to change the parameters of the profile. It will lead you step by step through each parameter, and allow you to change them as needed. You will enter the Profile Edit menu by pressing the "Edit" (Soft-key #1) from the main display. The menu will start with the choice of displaying temperatures in Fahrenheit or Celsius.

```
"Display is °F ?" or " Display is °C ?"
" Yes      No  "
```

- Pressing "Yes" (Soft-key # 1) will accept the display status and move on.
- Pressing "No" (Soft-key # 3) will change the temperature scale from Fahrenheit to Celsius and vice versa.

If the "Learn mode" capability was enabled in the Set-up menu, then the following choice will be displayed.

```
" Learn Mode? "  
" Yes          No  "
```

Pressing "Yes" (Soft-key # 1) will make the profile a "Learn" profile and move on to Preheat.  
Pressing "No" (Soft-key # 3) will take the profile out of "Learn Mode".

**K-type Thermocouple must be inserted Thermocouple input in the back of the system**

```
" Preheat On?  "  
" Yes         No  "
```

Pressing "Yes" (Soft-key # 1) will turn on the Pre-heat stage, and bring up the following menu.  
Pressing "No" (Soft-key # 3) turn off the Pre-heat, and move to the Soak option.

```
"PH Top Power = XX " XX = power of top heater, 00 = Off, 20 = Max  
" Yes Back Exit  "
```

Pressing "Yes" (Soft-key # 1) will accept the display status and move on to the next option.  
Pressing "Back" (Soft-key # 2) will take you back to the beginning of the Edit menu.  
Pressing "Exit" (Soft-key # 3) will exit the Edit menu and save all changes.  
Red Up and Blue Down keys will adjust Pre-Heat stage Top heater power.

```
"PH Lower Temp = XXX°F" XXX = Temperature of Lower heater(150°F to 350°F)  
" Yes Back Exit  " (65°C to 176°C)
```

Pressing "Yes" (Soft-key # 1) will accept the display status and move on to the next option.  
Pressing "Back" (Soft-key # 2) will take you back to the beginning of the Edit menu.  
Pressing "Exit" (Soft-key # 3) will exit the Edit menu and save all changes.  
*Red Up and Blue Down keys will adjust Lower Pre-Heat temperature.*

If profile is a Learn profile, then the following target temperature option will come up.

```
"PH Target = XXXF" XXX = Temperature Pre-heat stage target.  
" Yes Back Exit  "
```

Pressing "Yes" (Soft-key # 1) will accept the display status and move on to the next option.  
Pressing "Back" (Soft-key # 2) will take you back to the beginning of the Edit menu.  
Pressing "Exit" (Soft-key # 3) will exit the Edit menu and save all changes.  
Red Up and Blue Down keys will adjust Pre-heat Target temperature.

```
" Soak On?"  
" YesNo  "
```

Pressing "Yes" (Soft-key # 1) will turn on the soak stage, and bring up the following menu.  
Pressing "No" (Soft-key # 3) will turn off the soak stage, and move to the Reflow option.

```
"Soak T Power = XX " XX = power of top heater, 00 = Off, 20 = Max  
" Yes Back Exit  "
```

Pressing "Yes" (Soft-key # 1) will accept the display status and move on to the next option.  
Pressing "Back" (Soft-key # 2) will take you back to the beginning of the Edit menu.  
Pressing "Exit" (Soft-key # 3) will exit the Edit menu and save all changes.  
Red Up and Blue Down keys will adjust Soak Top heater power.

"Soak LT = XXX°F" XXX°F = Temperature of Lower heater (150°F to 350°F)

**" Yes Back Exit "**

**(65°C to 176°C)**

Pressing "Yes" (Soft-key # 1) will accept the display status and move on to the next option.  
Pressing "Back" (Soft-key # 2) will take you back to the beginning of the Edit menu.  
Pressing "Exit" (Soft-key # 3) will exit the Edit menu and save all changes.  
Red Up and Blue Down keys will adjust Lower Soak temperature.

If profile is a Learn profile, then the following target temperature option will come up.

**"Soak Target = XXXF" XXXF = Temperature Soak stage target.**  
**" Yes Back Exit "**

Pressing "Yes" (Soft-key # 1) will accept the display status and move on to the next option.  
Pressing "Back" (Soft-key # 2) will take you back to the beginning of the Edit menu.  
Pressing "Exit" (Soft-key # 3) will exit the Edit menu and save all changes.  
Red Up and Blue Down keys will adjust Soak Target temperature.

**" Reflow On? "**  
**" Yes No "**

Pressing "Yes" (Soft-key # 1) will turn on the reflow stage, and bring up the following menu.  
Pressing "No" (Soft-key # 3) will turn off the reflow stage, and move to the Dwell option.

**"Reflow Top Power = XX" XX = power of top heater, 00 = Off, 20 = Max**  
**" Yes Back Exit "**

Pressing "Yes" (Soft-key # 1) will accept the display status and move on to the next option.  
Pressing "Back" (Soft-key # 2) will take you back to the beginning of the Edit menu.  
Pressing "Exit" (Soft-key # 3) will exit the Edit menu and save all changes.  
Red Up and Blue Down keys will adjust Reflow Top heater power.

**"Reflow LT = XXXF" XXX = Temperature of Lower heater (150°F to 350°F)**  
**" Yes Back Exit " (65°C to 176°C)**

Pressing "Yes" (Soft-key # 1) will accept the display status and move on to the next option.  
Pressing "Back" (Soft-key # 2) will take you back to the beginning of the Edit menu.  
Pressing "Exit" (Soft-key # 3) will exit the Edit menu and save all changes.  
Red Up and Blue Down keys will adjust Lower Reflow temperature.

If profile is a Learn profile, then the following target temperature option will come up.

**"Reflow Target = XXXF" XXX = Temperature Soak stage target.**  
**" Yes Back Exit "**

Pressing "Yes" (Soft-key # 1) will accept the display status and move on to the next option.  
Pressing "Back" (Soft-key # 2) will take you back to the beginning of the Edit menu.  
Pressing "Exit" (Soft-key # 3) will exit the Edit menu and save all changes.  
Red Up and Blue Down keys will adjust Reflow Target temperature.

The dwell time is a time that the system will dwell at the Reflow temperature.

**" Dwell On? "**  
**" Yes No "**

Pressing “Yes” (Soft-key # 1) will turn on the dwell stage, and bring up the following menu.

Pressing "No" (Soft-key # 3) turn off the dwell stage, and move to the Install, Remove option.

```
"Dwell = XXX Sec "   XXX = Seconds of dwell stage.  
" Yes  Back Exit "
```

Pressing "Yes" (Soft-key # 1) will accept the display status and move on to the next option.

Pressing "Back" (Soft-key # 2) will take you back to the beginning of the Edit menu.

Pressing "Exit" (Soft-key # 3) will exit the Edit menu and save all changes.

Red Up and Blue Down keys will adjust dwell time in seconds

The install or remove setting will determine if the vacuum pick will be turned on to Remove a component or off to Install, five seconds before the end of the Reflow stage.

```
"Install/ Remove?"
```

Pressing "Install" (Soft-key # 1) will put the profile into an Install status, and it brings up the following menu.

Pressing "Remove" (Soft-key # 3) put the profile into a Remove status, and it brings up the following menu.

The Auto vacuum setting will enable the pick vacuum to be turned on or off five seconds before the end of the Dwell stage. If there is no Dwell phase, the vacuum will turn on automatically five seconds before the end of Reflow.

```
" Auto Vac = On " or " Auto Vac = Off "  
" Yes          No  "
```

Pressing "Yes" (Soft-key # 1) will accept the Auto Vacuum status, and bring up the following menu.

Pressing "No" (Soft-key # 3) will change the Auto Vacuum option from "On" or "Off".

The Head distance setting appears and reminds the operator of the current setting of the distance from the PCB. The head distance on the display screen should match where the top heater is aligned on the column/shaft; if it reads "1.0", align the top heater at "1.0" on the column and lock in place during cycle.

```
"Head Distance = XXX In"  
" Yes  Back Exit "
```

Pressing "Yes" (Soft-key # 1) will accept the Head Distance, and exit the Edit menu and save all changes.

Pressing "Back" (Soft-key # 2) will take you back to the beginning of the Edit menu.

Pressing "Exit" (Soft-key # 3) will exit the Edit menu and save all changes.

Red Up and Blue Down keys will adjust Head distance by tenths of an inch.

*\*\*In a Learn Profile, the system will automatically save the time it takes to reach the target temperature in each profile phase.*

## 11. Profile Save Menu:

This menu is used to save a profile to memory after edits to a profile have been made, and is entered by pressing the Save key (Soft-key # 2) from the main display.

```
" Save Profile "  
"Enter      Exit"  <->  " Number XX "  XX = profile to save to.
```

Pressing "Enter" (Soft-key # 1) will save the profile into the memory location, and return to main menu.

Pressing "Exit" (Soft-key # 3) will exit without saving profile.

Red Up and Blue Down keys will adjust the memory location to be saved to.

## 12. Profile Recall Menu:

This menu is used to recall a profile to memory, and is entered by pressing the Recall key (Soft-key # 3) from the main display.

" Recall Profile "  
 "Enter            Exit"    <->    "    Number XX    "    XX = profile recall from.

Pressing "Enter" (Soft-key # 1) will recall the profile from the memory location, and return to main menu.  
 Pressing "Exit" (Soft-key # 3) will exit without recalling profile.

Red Up and Blue Down keys will adjust the memory location to be recalled from.

**Note: When you try and recall a profile that does not exist, the display will read: "Profile does not exist"**

## 13. Maintenance

**Caution: Disconnect the main power supply and computer cables before opening the BGA, replacing any component or before performing any routine maintenance.**

- a. Periodically inspect the power cords and other cables for signs of wear or damage. If wear or damage is found, replace the cord or cable immediately.
- b. The work surface and housing should be cleaned periodically with a soft damp cloth.

## 14. Vacuum pick replacement. (Reference Figure 3)

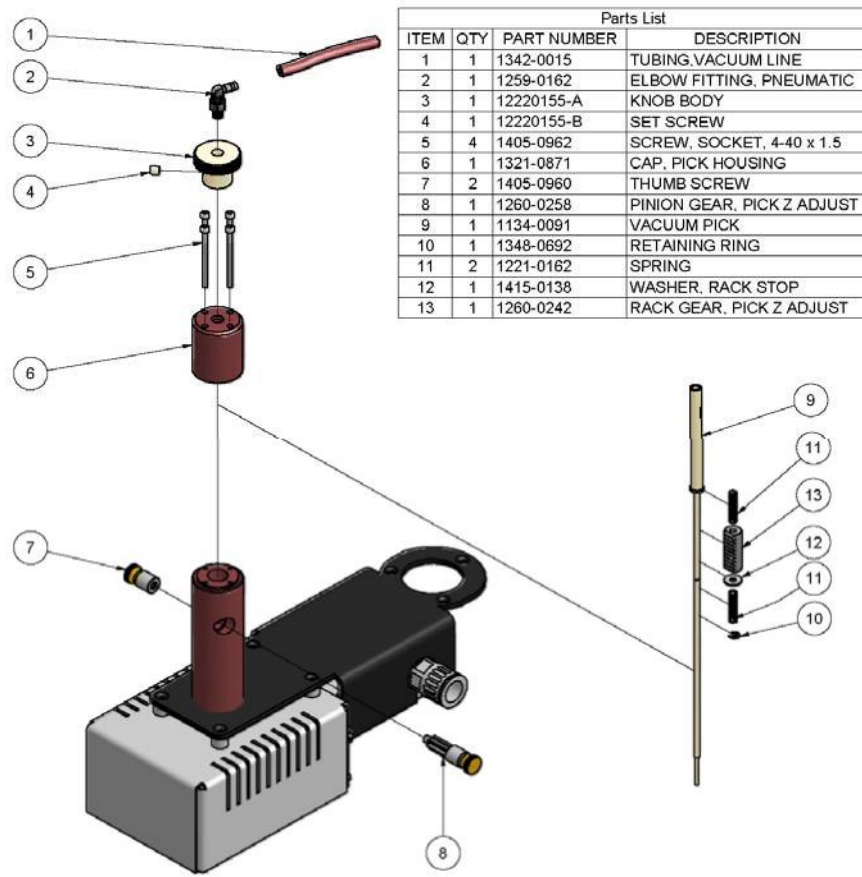

Fig 3



- A. Remove vacuum tubing line (1) and unscrew elbow fitting (2) from top of pick.
- B. Remove knurled knob (3) by loosening set screw (4).
- C. Remove 4 socket head screws (5).
- D. Remove black cap (6) from pick housing.
- E. Unscrew and remove vertical adjustment mechanism (7) and (8).
- F. Remove pick (9) from pick housing.
- G. Remove small snap ring (10) from groove on pick and slide off 2 springs (11), washer (12) and rack gear (13), noting assembly order. Reassemble on new pick.
- H. Installation is reverse of removal.

15. **IR Heater Elements replacement. (Reference Figure 4)**

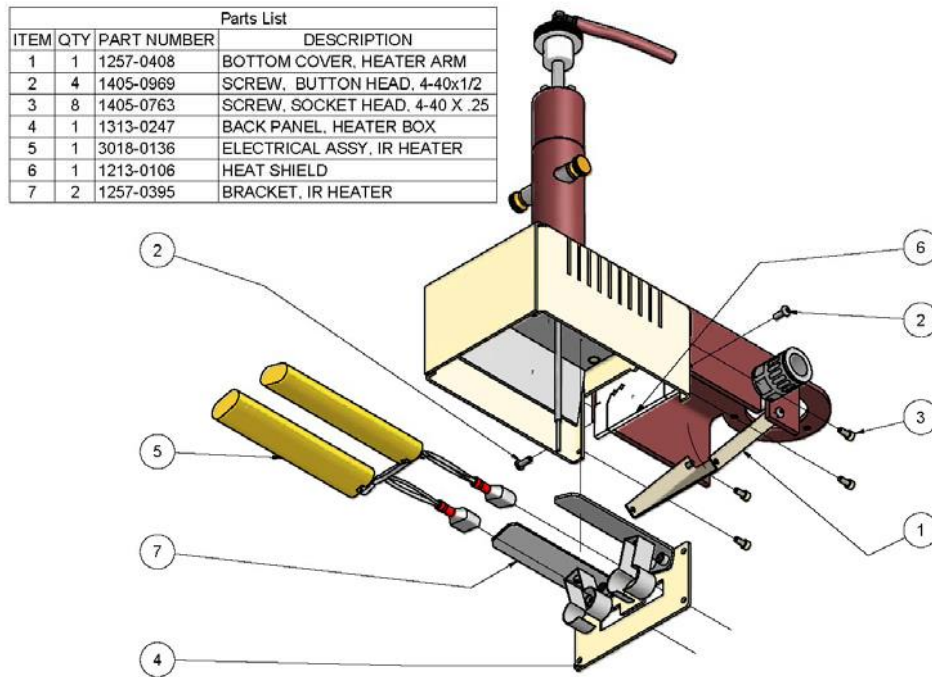

Fig 4

- A. Open heater bottom cover (1) by loosening 2 front screws (2).
- B. Remove 4 screws (3) and slide out rear panel (4) with attached heater assembly (5). Disconnect 2 electrical connections. Note how cabling passes through heat shield (6)
- C. Loosen 2 clamps (7) and remove heater elements.
- D. Installation is reverse of removal.

16. **Troubleshooting**

Maintenance beyond this should only be completed by a qualified PACE service technician.

Symptom	Probable Cause	Solution
No power to system	System not Plugged in to AC	Plug system into power outlet.
	Main Fuse blown	Replace fuse

<i>No power to heaters</i>	<i>Heater Fuse Blown</i>	<i>Replace fuse</i>
<i>No Vacuum to Main Pik</i>	<i>Vacuum Hose up-plug in back</i>	<i>Plug in vacuum hose</i>

## **17. IR 1000 Manual Abbreviations**

**IR:** Infra-Red

**PCB:** Printed Circuit

Board **LED:** Light-

Emitting Diode **BGA:**

Ball Grid Array

**PBGA:** Plastic Ball Grid Array

**CBGA:** Ceramic Ball Grid Array

**CSP:** Chip Scale Package

**LGA:** Land Grid Array

**QFN:** Quad Flat No Leads

**SMD:** Surface Mount Devices

**LCC:** Leadless Ceramic Carrier

**Soft Keys:** Black buttons on front of machine.

**VAC:** Vacuum

## **18. Service and Warranty**

Please contact PACE or your local distributor for service and repair

### **LIMITED WARRANTY**

Seller warrants to the first user that products manufactured by it and supplied hereunder are free of defects in materials and workmanship for a period of one (1) years from the date of receipt by such user. Blowers and motor pumps (which wear out during normal use) are warranted for a period of one (1) year.

This warranty does not cover wear and tear under normal use, repair or replacement required as a result of misuse, improper application, mishandling or improper storage. A consumable item such as tips, heaters, filters, etc. which wear out under normal use are excluded. Failure to perform recommended routine maintenance, alterations or repairs made other than in accordance with Seller's directions, or removal or alteration of identification plates in any way will void this warranty. This warranty is available only to the first user, but the exclusions and limitations herein apply to all persons and entities.

SELLER MAKES NO OTHER WARRANTY, EXPRESS OR IMPLIED, AND MAKES NO WARRANTY OF MERCHANTABILITY OR FITNESS FOR A PARTICULAR PURPOSE.

Seller will, at its option, repair or replace any defective products at its facility or other location approved by it at no charge to user, or provides parts without charge for installation by the user in the field at user's expense and risk. User will be responsible for all costs of shipping equipment to Seller or other location for warranty service.

EXCEPT FOR THE REMEDY ABOVE DESCRIBED, UNLESS OTHERWISE REQUIRED BY APPLICABLE LAW, SELLER WILL HAVE NO OTHER OBLIGATION WITH REGARD TO ANY BREACH OF WARRANTY OR OTHER CLAIM WITH RESPECT TO THE PRODUCTS, OR LIABILITY FOR ANY DIRECT, INDIRECT, CONSEQUENTIAL, OR INCIDENTAL LOSS OR DAMAGE CAUSED BY OR OCCURRING IN CONNECTION WITH ANY OF THE PRODUCTS.

Warranty service may be obtained by contacting the appropriate PACE Company or local Authorized PACE distributor as set forth below to determine if return any item is required or, if repairs can be made, by the user in the field.

Defective products may not be returned to PACE without a Service Authorization ("SA") Number.

Any warranty or other claim with respect to the products must be made in writing delivered to PACE (or local Authorized PACE distributor for Buyers outside the USA and the United Kingdom) within a reasonable time of the expiration date of this warranty with sufficient evidence of purchase and date of receipt, otherwise user's rights under this warranty shall be deemed waived.

PACE Incorporated retains the right to make changes to specifications contained herein at any time, without notice. Contact your local authorized PACE Distributor or PACE Incorporated to obtain the latest specifications.

The following are trademarks and/or service marks of PACE, Incorporated, NC,

USA. INSTACAL<sup>®</sup>, FUMEFLO<sup>®</sup>, HEATWISE<sup>®</sup>, PACEWORLDWIDE<sup>®</sup>,

PERMAGROUND<sup>®</sup>,  
POWERMODULE<sup>®</sup>, and TEMPWISE<sup>®</sup>

The following are registered trademarks and/or service marks of PACE Incorporated, Southern Pines, North Carolina, U.S.A.

ARM-EVAC<sup>®</sup>, FLO-D-SODR<sup>®</sup>, MINIWAVE<sup>®</sup>, PACE<sup>®</sup>, SENSATEMP<sup>®</sup>, SNAPVAC<sup>®</sup>, SODRTEK<sup>®</sup>, SODR-X-TRACTOR<sup>®</sup>, THERMOFLO<sup>®</sup>, THERMOJET<sup>®</sup>, THERMOTWEEZ<sup>®</sup>, and VISIFILTER<sup>®</sup>

PACE products meet or exceed all applicable military and civilian EOS/ESD, temperature stability and other specifications including MIL STD 2000, ANSI/JSTD 001, IPC7711, and IPC A-610.



**PACE Incorporated**  
255 Air Tool Drive  
Southern Pines,  
North Carolina, 28387  
Tel: (877) 882-PACE  
Tel: (910) 695-7223  
Fax: (910) 695-1594

**Pace Europe**  
11 Holdom Avenue  
Bletchley, Milton Keynes,  
United Kingdom, MK11QU  
Tel: 011 44 1908 277666  
Fax: 011 44 1908 277777